

PRODUCT SPECIFICATION SHEET



General Characteristics

Brand : LinkedPro
Code : LPREP0804
Description : 19" open rack 4-unit

Physical Characteristics

Material : Rolled steel sheet
AWG : 18
Color : Black
Application : Interior

Electrical Characteristics

Input voltage : NA
Output voltage : NA
Consumption : NA

Dimensional Characteristics

Width : 492 mm
Height : 200 mm
Depth : 200 mm
Weight : 1.40 Kg
Suggested Load Max : 21 Kg

Special Characteristics:

Electrostatic powder paint

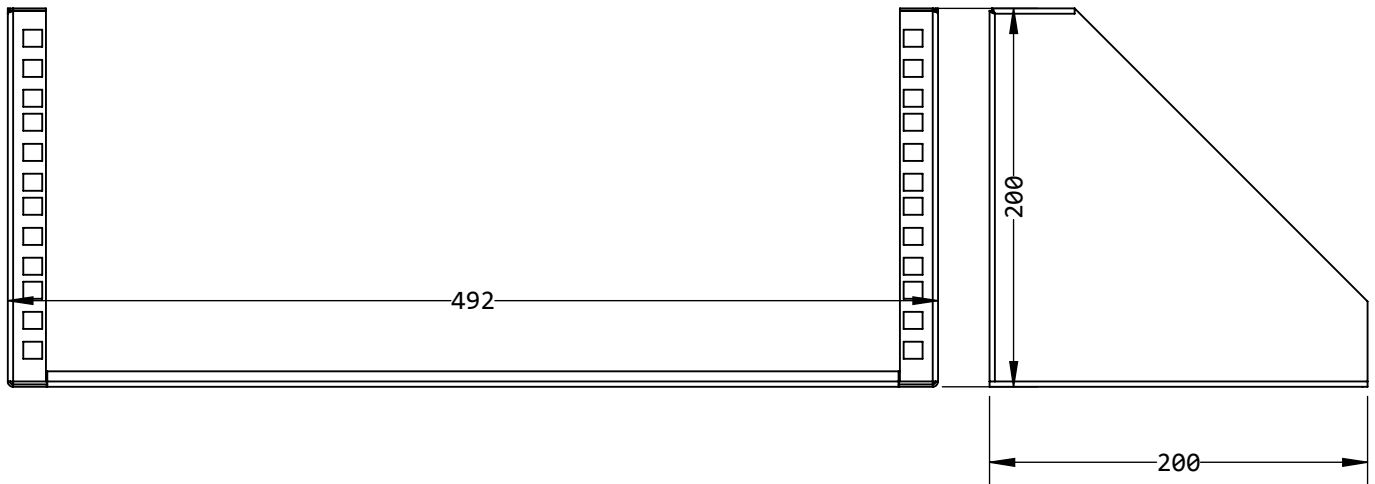
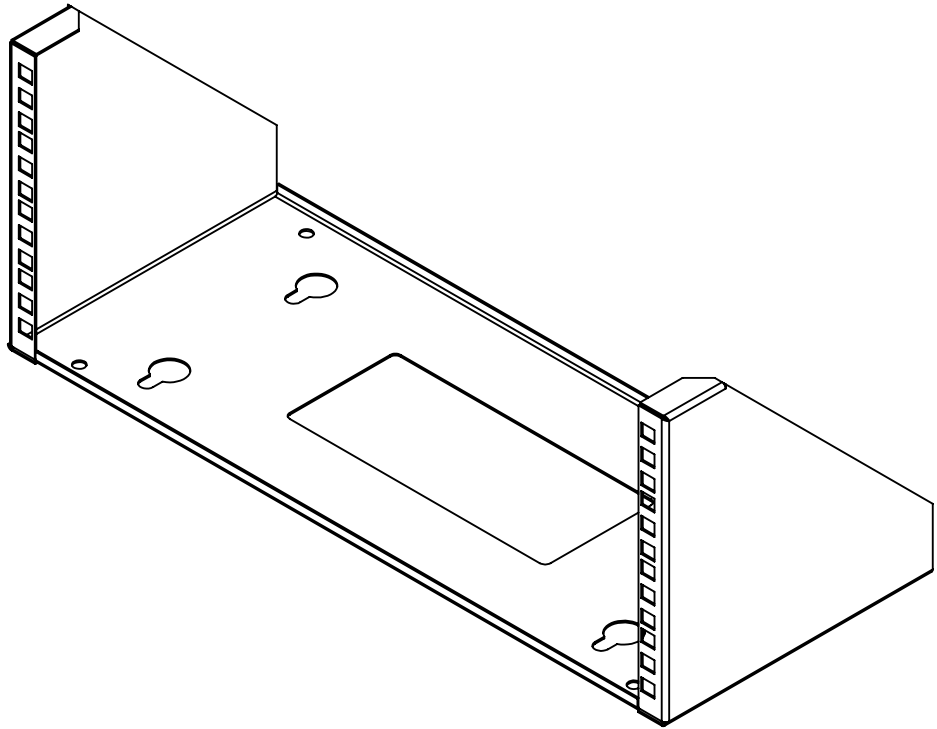

Review date : 12/11/15

Rev : 001

Made by : S. Quintana

Rev description :

New Product

Authorized :

Reference document : DOC 7.5.1 002/164 MTM

* The colors of the products may change due to technical improvements.

* The declared weight of the equipment is without accessories and without packaging.

SISTEMAS Y SERVICIOS DE COMUNICACIÓN S.A. DE C.V.
Calle 20 de Noviembre #805, Col. Centro (614) 415-25-25