

Installation Guide

Version: 1.0 Date: June, 2012

1. Equipment Installation

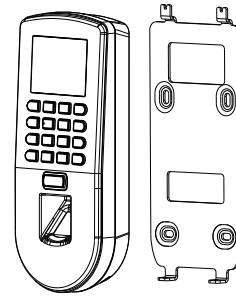
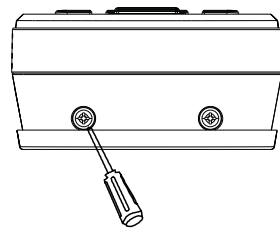
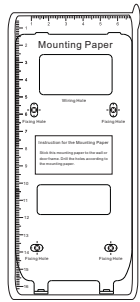

- (1) Paste the mounting template on the wall. Drill the holes according to the marks on the template (holes for screws and wiring).
- (2) Remove the screw on the bottom of device.
- (3) Take away the back plate.

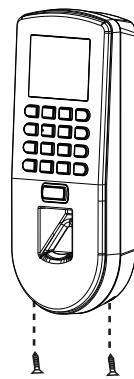
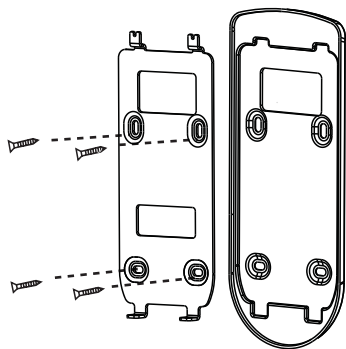

- (4) Fix the rubber pad and the back plate on the wall according to the mounting paper.
- (5) Place the unit onto the mounting bracket, and tighten the screw at the bottom of the unit.

2. Structure and Function

Access Control System Function

- (1) If a registered user verified, the device will send a signal to unlock the door.
- (2) The door sensor will detect the ON-OFF state. If the door is unexpectedly opened or improperly closed, the alarm signal (digital value) will be triggered.
- (3) If the device is illegally removed, the device will signal the alarm.
- (4) External card reader is supported.
- (5) External exit button is supported.
- (6) External door bell is supported.
- (7) Supports RS485, TCP/IP communication to be able to connect with PC. One PC can manage multiple devices.

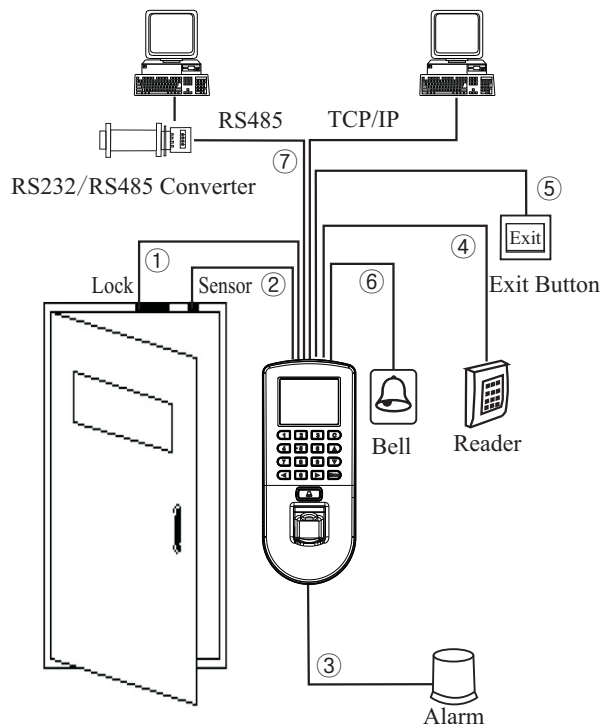

* All rights reserved.

3. Lock Connection

(1) Share power with the lock:

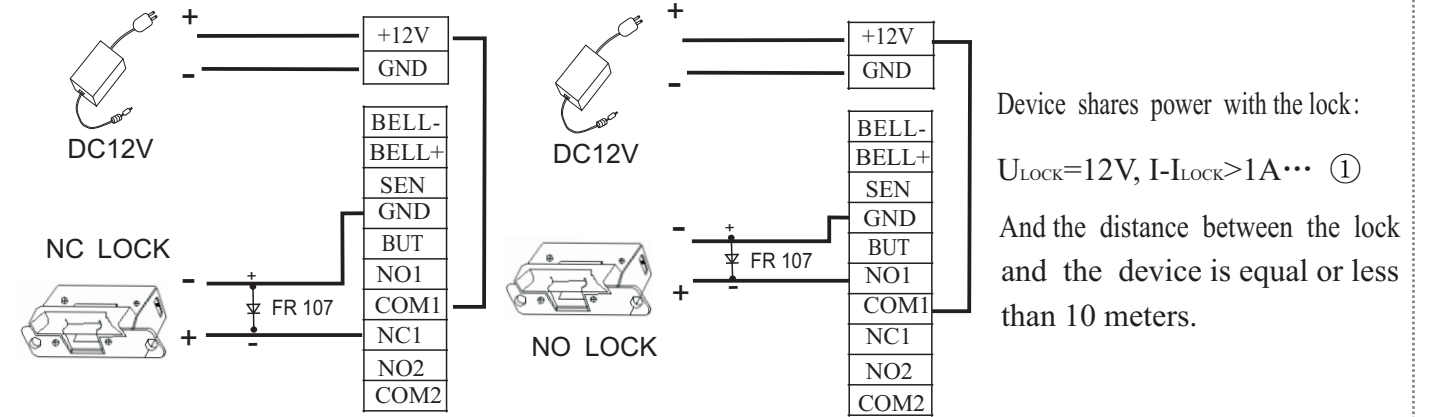

(2) Does not share power with the lock:

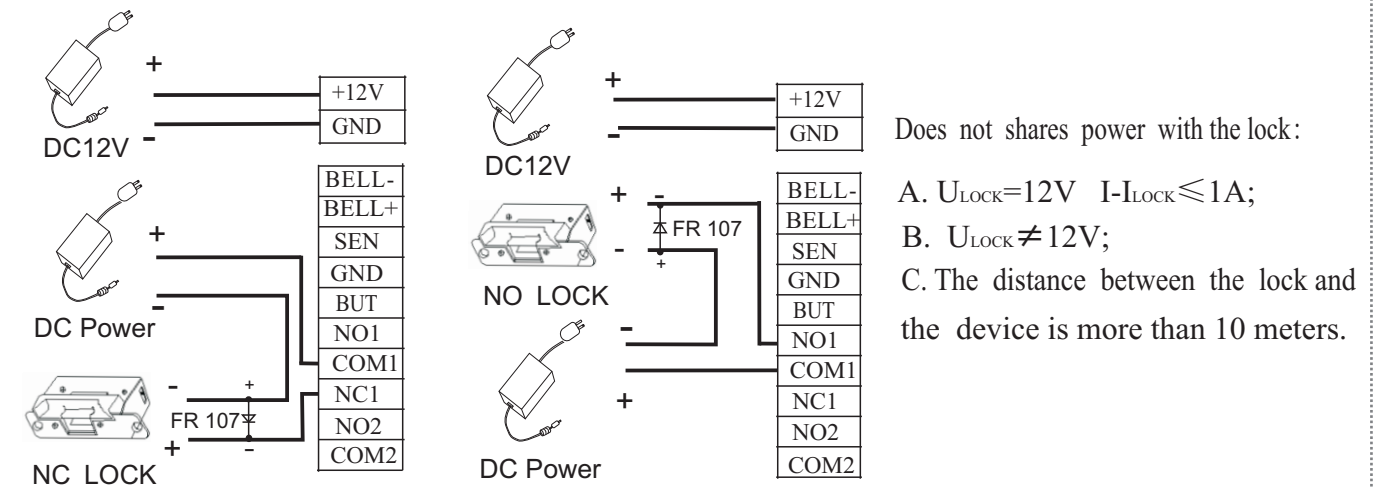

- (1) The system supports NO LOCK and NC LOCK. For example the NO LOCK (normally open at power on) is connected with 'NO' and 'COM' terminals, and the NC LOCK (normally close at power on) is connected with 'NC' and 'COM' terminals.
- (2) When the Electrical Lock is connected to the Access control System, you need to connect one FR107 diode (shipped in the package) in parallel with the connection to prevent the self-inductance EMF feedback the system. **NB: Do not reverse the polarities!**

4. Other Connections

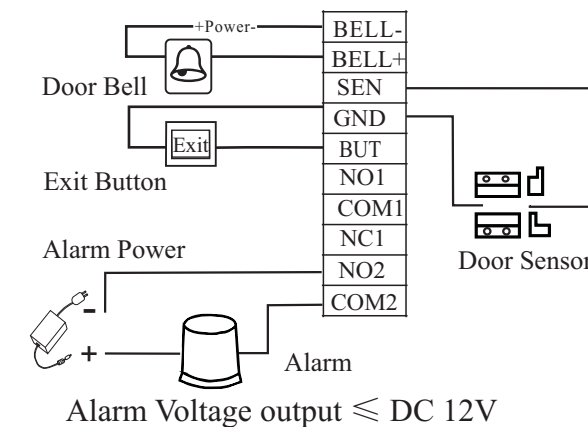

$\textcircled{1}$: 'I': device output current, ' U_{LOCK} ': lock voltage, ' I_{LOCK} ': lock current

5. Power Connection

The device working voltage DC 12V, electric current 500mA (50mA standby). Positive is connected with '+12V', negative is connected with 'GND'.
(Do not reverse the polarities)

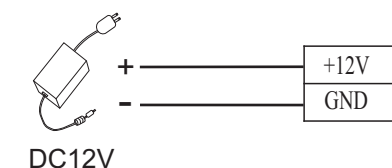

WARNING: Do Not operate with Power connected.

6. Wiegand Output

The device supports standard Wiegand, 26-bit output, so you can connect it with various access control devices.

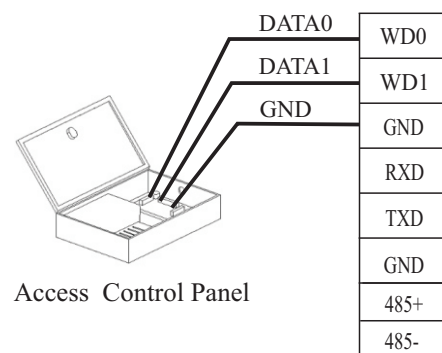

- (1) Do not exceed 90m(meters) distance between the Device and Access Control Lock OR Card reader. (In case of long distance installation, use the Wiegand Signal Extender to minimise interference).
- (2) To keep a balanced and stable Wiegand signal, connect the device, access control lock and card reader on the same 'GND' (ground) port.

7. Wiegand Input

The device has a Wiegand input port, which enables the connection to a slave card reader. Device are control devices on both sides of the door to control the access and electric lock.

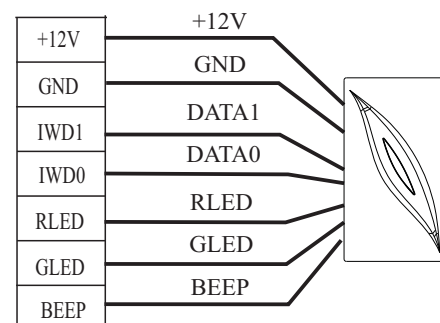

8. Other Functions

(1) Manual Reset:

If the device does not work properly because of misoperation or other abnormality, you can use 'Reset' function to restart it.

Operation: Remove the black rubber cap, then stick the Reset button hole with a sharp tool (the tip diameter is less than 2mm).

(2) Restore Factory Settings:

You can use the tamper switch to restore factory settings, such as device number, system password, IP address, RS485 address, etc. The user data won't be cleared.

Operation: 30-60 seconds after the tamper alarm has sounded, press the tamper switch three times.

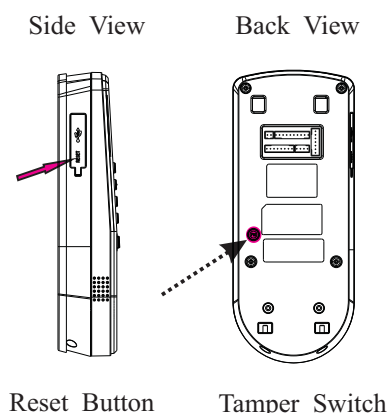

9. Communication

There are three modes that the PC software could communicate and exchange information with the device: RS485 and TCP/IP, and supports remote control.

1. RS485 Mode:

Please use specified RS485 wire, RS232/485 active converter, which consists of bus-type wiring.

If the communication wire is longer than 100meters, you need to parallel a terminal resistance on the receiving end, and resistance value is about 120 ohm.

Terminals	PC Serial Ports
GND	Pin5-Gnd
RXD	Pin3-Txd
TXD	Pin2-Rxd

RS485Reader:

Equipment supports 485reader function, can be through the 485communication connected to FR1200 reader; meanwhile, it can act as Master-slaver which device for master, FR1200 reader for slaver, achieve 485 Anti-passback functions. If select "485reader function", so device can not connect with PC through 485 communications.

Diagram of RS485Reader Function (Right)

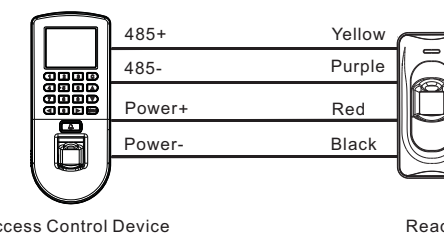

Communications of PC:

Please use specified RS485 wire, RS485 active converter and bus-type wiring.

Terminals:

Terminals	PC Serial Ports
485+	RS485+
485-	RS485-

2. TCP/IP Mode:

About the terminals definition, please refers to the right table.

Two ways for TCP/IP connection:

(A) Crossover cable: The device and PC connected directly.

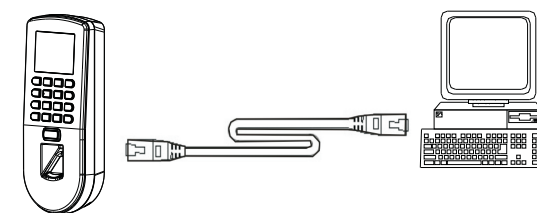

IP Address: 192.168.1.201 IP Address: 192.168.1.124
Subnet Mask: 255.255.255.0 Subnet Mask: 255.255.255.0

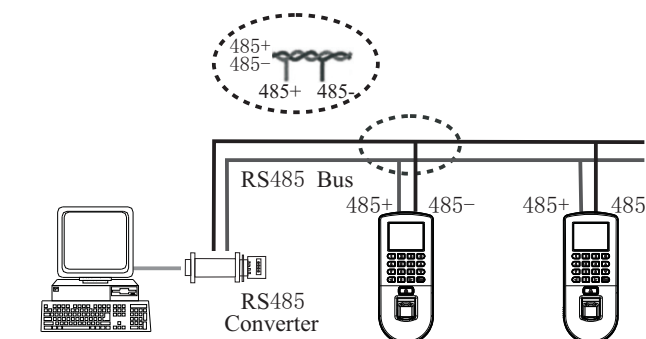

Terminals	Wire Name	Color
RJ45-1	TX+	White-orange
RJ45-2	TX-	Orange
RJ45-3	RX+	White-green
RJ45-6	RX-	Green

(B) Straight cable: The device and PC connected to LAN/WAN through switch/Lan switch.

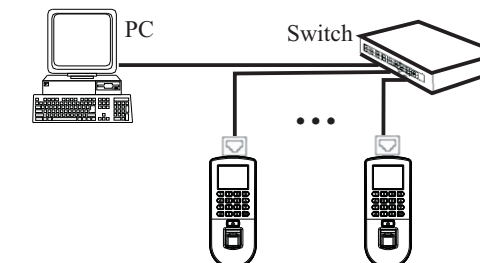

10. Cautions

- (1) **Connect the power cable after all the wiring has been completed.** If the device is working abnormally, please shut down the device, and make necessary checks. Please note that any "HOT SWOP" of wiring on the device may damage the device, and the warranty does not cover damage caused by improper operations.
- (2) We recommend **use the DC 12V/3A power supply.** Please contact our technical staff for details.
- (3) **Please read the terminal and wiring description and diagrams carefully before commencing with installations.** Any damage to the device caused by improper operations, will not be covered under warranty.
- (4) **Keep the exposed part of wire less than 5mm,** to avoid unexpected connection.
- (5) **Please connect the 'GND'** when starting installations, especially in an environment where static electricity is very high.
- (6) **Do not change the cable type** in case of a long distance installations.

