

Intelligent Road Barrier Instruction Manual

XB5000/6000

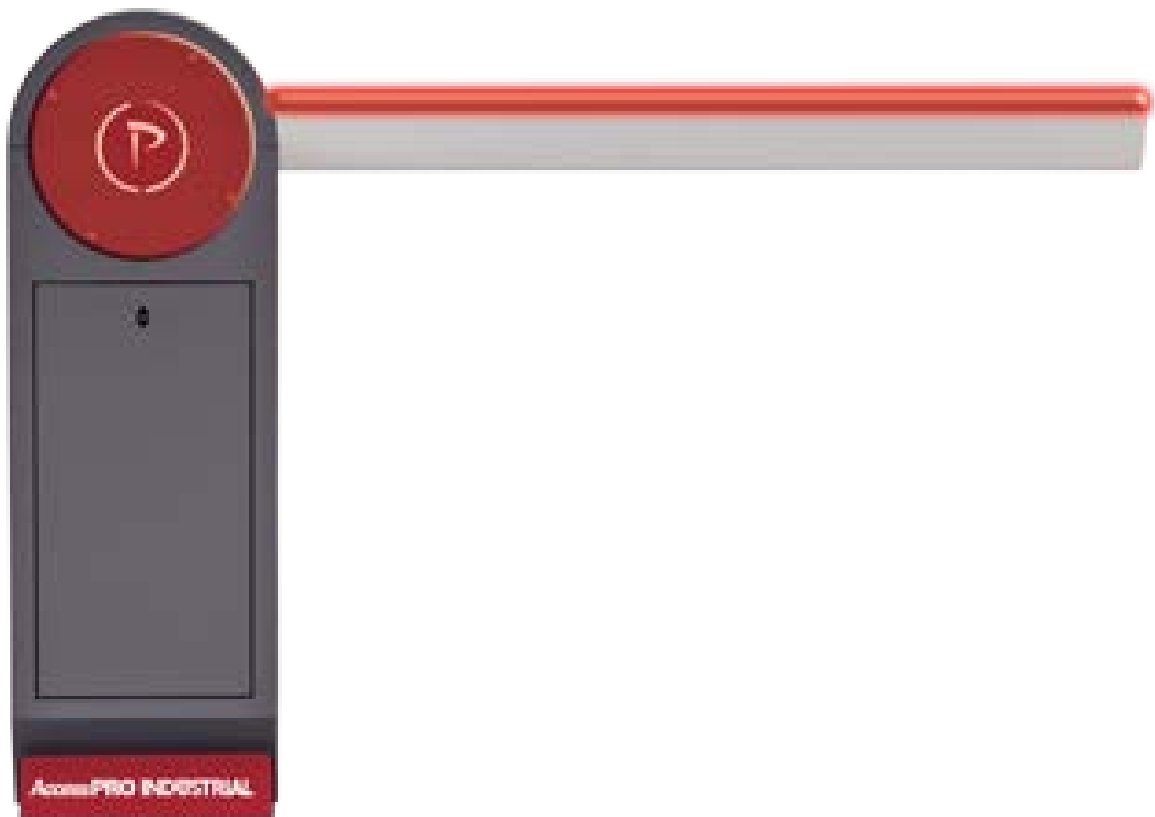

Warning:

Be sure to read this manual before installation. Important information involving safety, installation, utilization and maintenance are included.

For easy reading, the content stated here is of the same order with installation steps. Any different operations not mentioned in this manual are not allowed. Improper use will probably cause damage to the product, or even people and property.

Considering the potential danger which may occur during the installation and utilization process of B60, the construction standards and electric operation specifications must be strictly complied during installation, especially the following items:

- Check whether additional devices or materials are needed before installation to meet specific demand.
- The dispose of packing materials must comply with local laws.
- Do not apply any modification to any part except for those mentioned in this manual. Unexplained modification may cause mechanical failure. We are not responsible for any damage caused by improper or different use from the indicated one.
- Do not soak automatic parts in the water or any other kinds of liquid. Ensure that the liquid don't leak into controller or other opening devices during installation.
- Please cut off the power instantly and contact our customer service department in the case of liquid splashing into automatic device. Continuing using B60 road barrier is extremely dangerous under such circumstance.
- Keep B60 far away from heat resource and open fire; otherwise it may damage the elements and cause failure, or even fire hazard or other dangers.
- Please take out the standby batteries and keep it in dry places in case of harmful substance leakage.
- Controller power must have safe ground.
- All operations needing to open the box of B60 road barrier should have the power cut off first. Please stick a warning sign reading WARNING: DEVICE IN MAINTENANCE if the circuit breaker is difficult to ensure.
- Forbid pedestrian standing and walking under the lever when it is working. When the lever is hit to twirl 90° , any pedestrian standing and objects placing in that scope is forbidden.
- Observe the lever working condition and ambient conditions during operation. Do not stop it from working except for special situation.
- Cut off the power and raise the lever in the case of blackout. Plug in when power recovers.
- Spring adjustment, running mode setting and infra-red detector installation must be

operated by professionals.

□ Since the anode and cathode of motor connect with large capacitance, people should keep away from high voltage pressure region during power off time to avoid electric shock.

Catalogue

<u>1.Standard Spare Parts List</u>	<u>3</u>
<u>2.Brief Product Info.</u>	<u>3</u>
<u>3. Electric Part</u>	<u>4</u>
<u>4.Pre-installation Preparation</u>	<u>11</u>
<u>5.Installation</u>	<u>12</u>
<u>6.Regular Problems&Solutions</u>	<u>14</u>
<u>7.Maintainance</u>	<u>15</u>

1. Standard Spare Parts List

No.	Name	Quantity
1	Barrier Box	1
2	Arm	1
3	Arm Fixer	1
4	Arm Fixer Bolt	4
5	Main Controller (Installed inside box)	1
6	Manual Control Box	1
7	Fix Board	2
8	Expansion Bolt M14×150	4
9	Bracket (only for arm≥4m)	1
10	Key	2

2. Brief Product Info.

- Art. No. : XB5000/XB6000
- Size : 360*315*1050mm
- Power : 250W 110VAC
- Voltage : 110V 60Hz
- Speed : 1.6S (XB6000)/6S(XB5000)
- Arm Length : Max 3m (XB6000) /Max 6m (XB5000)
- Connection : RS485
- Working Temperature : -25°C to 70°C
- Applied arm : Straight Arm

3. Electric Part

a. Electric Installation Instruction:

After wiring according to the diagram blow, install control devices and safety device.

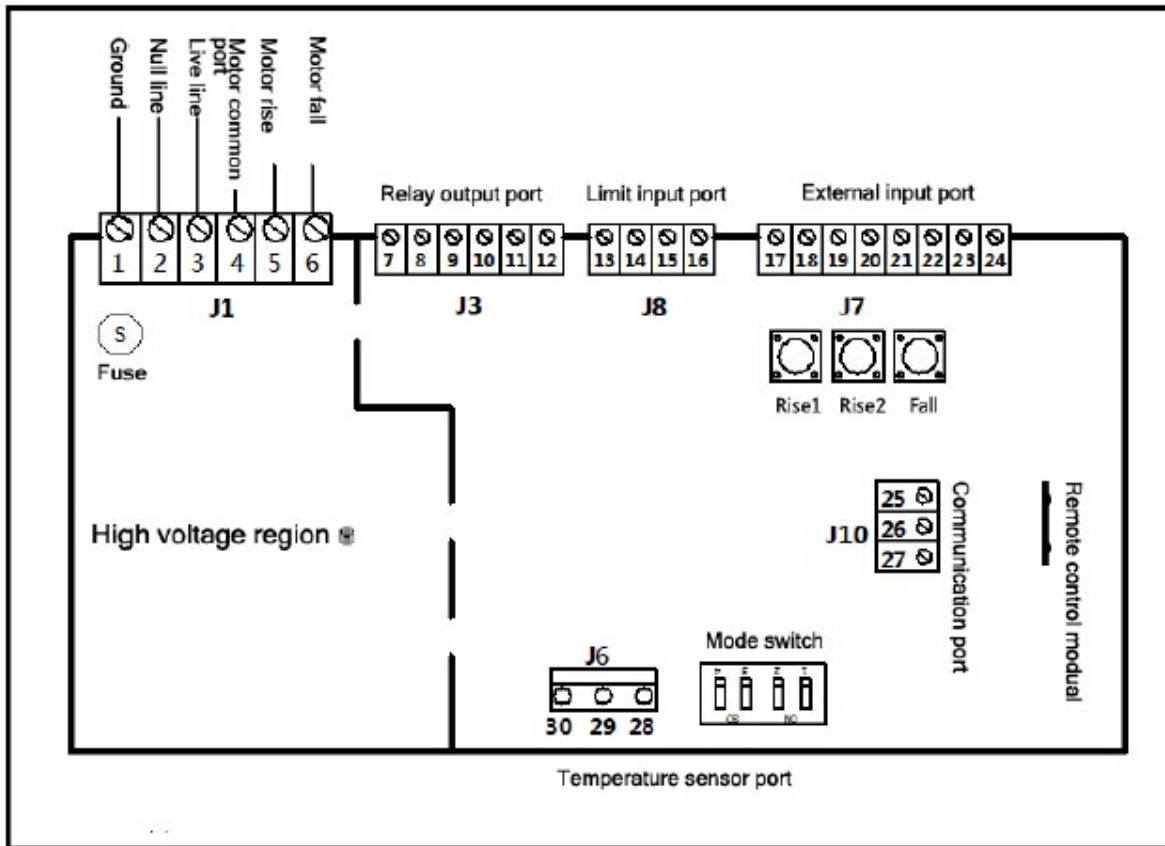

Wiring instruction: silk screen pedestal design number in bracket (symbol in correspondence with mainboard)

110V AC Power Port (J1)

SN	Function	Description
1	Ground	Earth Wire
2	Null Wire	AC110V Connect in
3	Live Wire	AC110V Connect in
4	Null Wire (Motor Commen Port)	Normally connect with the red wire of the motor
5	Motor Rise	Normally connect with the white wire of the motor
6	Motor Fall	Normally connect with the blue wire of the motor

Relay Output Port (J3)

SN	Function	Description(Relay could not supply the electricity and requires external power supply)

7	Relay 1 Normally Open Port	Could control cooling fan power or traffic light, depending on dial code mode.
8	Relay 1 Normally Close Port	
9	Relay 1 Common Port	
10	Relay 2 Normally Open Port	Could control traffic light or signal light, depending on dial code mode.
11	Relay 2 Normally Close Port	
12	Relay 2 Normally Common Port	
Limit Input Port (J8)		
SN	Function	Description
13	5V Output	No connection
14	Limit Up Input	Connect with red wire of limit line
15	Limit Down Input	Connect with blue wire of limit line
16	Ground	Connect with yellow&green wire of limit line
External Input Port (J7)		
SN	Function	Description
17	Ground	When low electrical level is in effect, signal exists only when input port is connected with the ground
18	Reservation	
19	Reservation	
20	Anti-collision(direction detection)	Rise the lever when there is anti-collision signal to avoid hitting cars (connect with ground sensor). Activate direction detection under automation mode 2.
21	In-direction Rise the Lever	Connect with relay NO port
22	Out-direction Rise the Lever	No connection
23	Lever fall	Can choose no connection; automatically fall the lever when anti-collision signal disappear
24	Ground	Connect with relay COM port
Communication Port (J10)		
SN	Function	Description

25	Ground	
26	RS485-	When communicate with upper computer, connect with RS485-
27	RS485+	When communicate with upper computer, connect with RS485+
Temperature Sensor Port (J6)		
SN	Function	Description
28	Ground	
29	Ground	
30	External Thermistor	Can temporarily not connect

Instructions: ground connection completes in one board.

Buttons on mainboard: in-direction lever rise button (Rise1) , out-direction lever rise button

(Rise2), lever fall button (Fall)

Remote button: lever rise (B, D), lever fall (A, C)

Motor input port: red wire (common port), white wire (motor rises the lever), blue wire (motor falls the lever)

Note: cooling fan = relay 1, single direction traffic light = relay 2, signal light = relay 2

Input port priority level: in-direction lever rise = out-direction lever rise > anti-collision > lever fall; no priority level concept in flow ground sensor

RS485 communication port: can set parameters including deferred fall lever time, deferred fan turnoff time after motor stops as well as in/out-direction lever rise/fall signals through upper computer.

b. Function Selection

Choose different function modes by the function switches.

1-OFF 2-OFF	Semi-automatic mode, input a pulse signal and continuously complete the lever rise/fall action.
1-OFF 2-O N	Manual mode, continuously press the pushbutton to make the road barrier work, loosen to stop.
1-O N 2-OFF	Automatic mode1, delay for default 0.5 second to fall the lever automatically after anti-smash input signal disappears (factory defaulted value).
1-O N 2-O N	Automatic mode2, flow detection, delay for default 20 seconds to fall the lever

3-OFF 4-OFF	Single access opens. Output port configuration: traffic light mode x2
3-OFF 4-O N	One in, one out, lever rise move complete mode. Output port configuration: signal light + cooling fan.
3-O N 4-OFF	One in, one out, output port configuration: traffic light + cooling fan.
3-O N 4-O N	One in, one out, output port configuration: signal light + cooling fan.

c. Function Introduction

The following is a brief statement of optional functions: all functions can be operative or inoperative by the restriction of any conditions.

*Note: In and out flow ground sensor signals of input ports in all modes have anti-collision effect. Take this into consideration before installation.

Switch 1-2: OFF, OFF = semi-automatic mode

OFF, ON = manual mode

ON,OFF = automatic mode 1 (factory defaulted value)

ON,ON = automatic mode 2

Under semi-automatic mode, just input one pulse signal and the road barrier will continuously complete lever rise/fall actions. Anti-smash input is in effect under this mode.

Under manual mode, road barrier only works when the pushbutton is continuously pressed.

Once loosen, it stops. Anti-smash input is in effect under this mode. Since the lever rise on remote control is in-direction rise, it is not allowed to stop the out-direction lever rise motion halfway and then use remote control or in-direction lever rise signal to rise the lever. To avoid troubles caused by this condition, we suggest installation personnel use manual mode together with lever rise complete mode. That is to set dial code3, 4 as off, on.

Under automatic mode1, the lever falls 0.5 second later after anti-smash input signal disappears. Anti-smash input is in effect under this mode.

Under automatic mode2, detect the flow, 20 seconds deferred to fall the lever. For

instance: if in-direction signal makes the barrier lever rise, the lever will automatically falls when geomagnetic detector detects that the vehicle has passed. When 3 in-direction lever rising signals are input, ensure the lever falls after geomagnetic detector detects 3 out-direction signals. Out-direction likewise. When anti-smash signal is input, the lever will remain in rise state.

Anti-smash input is in effect under this mode. Flow detection work method: when in-direction rise signal is input, car presses out-direction flow ground sensor at first, then simultaneously presses out-direction and in-direction flow ground sensors. Finally it presses in-direction flow ground sensor. That is one car flow counting.

Switch 3-4: OFF, OFF = single access enables

ON, OFF = one in, one out 1

OFF, ON = one in, one out 2 (factory defaulted value)

ON, ON = one in, one out 3

Single access enables: bi-directional traffic lights are used under this circumstance. When there's traffic in one direction, traffic lights will indicate vehicles in the opposite direction not to pass.

One in, one out 1: output port configuration: relay 2 outputs as traffic light, relay 1 outputs as cooling fan.

One in, one out 2: lever rise action complete mode, namely fall signal input invalid during lever rise process. Output port configuration: relay 2 outputs as signal light, relay 1 outputs as cooling fan.

One in, one out 3: output port configuration: relay 2 outputs as signal light, relay 1 as cooling fan.

d. Function Mode Instruction

Under automatic working mode (semi-automatic, automatic and normally-closed):

Input control signal at Rise 1, and the road barrier will make in-direction lever rise action.

After this action finishes, road barrier lever will be in unscheduled FREEZING state if control signal remains (timer). The lever only falls when control signal stops.

Input control signal at Rise 2, and the road barrier will make out-direction lever rising action.

After this action finishes, road barrier lever will be in unscheduled FREEZING state if control signal remains (timer). The lever only falls when control signal stops.

Input control signal at “Fall”, and the road barrier will make lever falling action. If this signal remains, road barrier will be always locked in the position where lever fall action stops. It is not until the signal disappears that the road barrier is allowed to make lever rise action.

e. Manual Control Box (RF-MOC-A) Wiring Instruction

There’re 3 effective wires in the manual control box. Their connections to signal input ports are as follows:

Yellow Wire	Lever rise input port
Red Wire	Lever fall input port
Black Wire	GND

Rise input port simultaneously connects with external input port in/out-direction rise signal input port; Fall input port connects with external input port fall signal input port; GND connects with external input port ground signal input port:

*Motorcade mode when red spin button is on: barrier remains in rise state

*Single mode when red spin button is off: barrier remains in swipe card control



f. Fierce Clutch

*We can set anti-crush sensor if you need.

* We can set LED if you need.

* Fierce clutch:

a. Our regular model is Release Model

b. When power off we can also control the barrier up & down, open the barrier cover and press the clutch handle then turn right you can control the barrier manually. (Actuation Model)

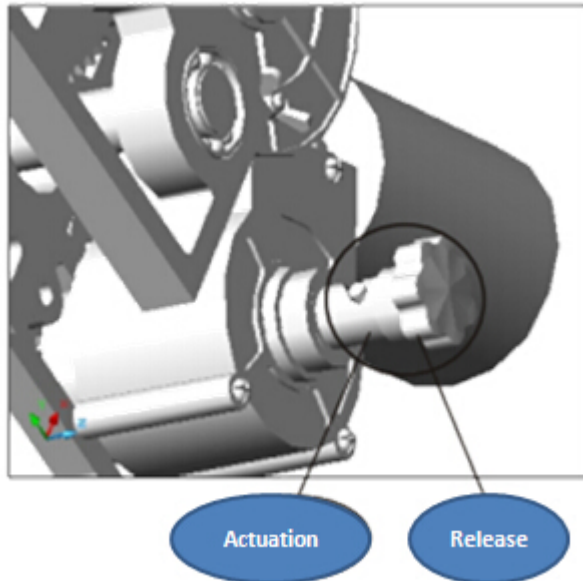

4. Pre-installation work

- * Check whether the mounted position is suitable for road barrier size. Notice: make sure to install the lever at right side or left side.
- * Check about obstacles to avoid hindering the running of the lever.
- * Check about mount set firmness and size of road barrier.
- * Check whether the road barrier mounted position is suitable for convenient and safe running.

Following is the drawing of base:

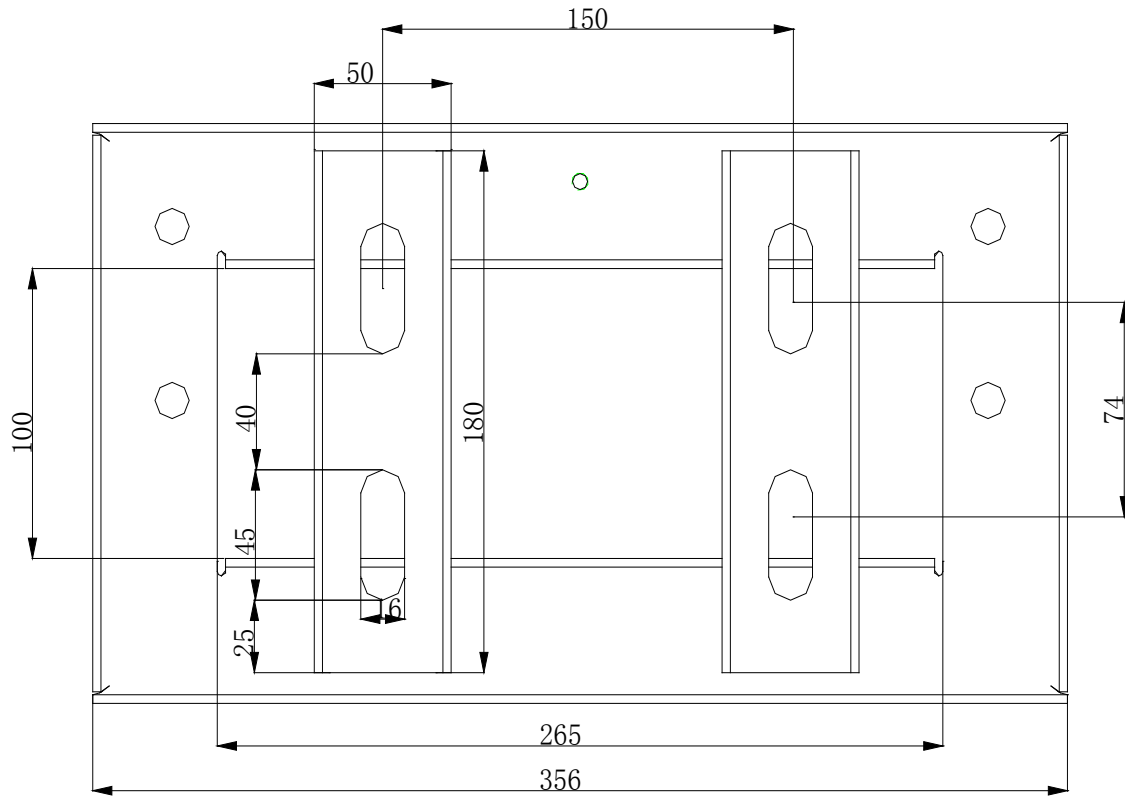

5. Installation

Make sure the install place of barrier - Install 4pcs expansion bolt to right place(the depth of bolt hole need 80-100mm) then fixed the bolt – following the drawing to install the base:

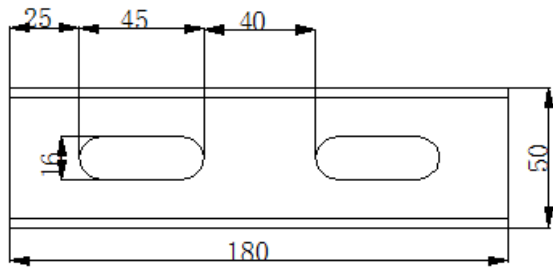

4 pcs expansion bolt drawing:

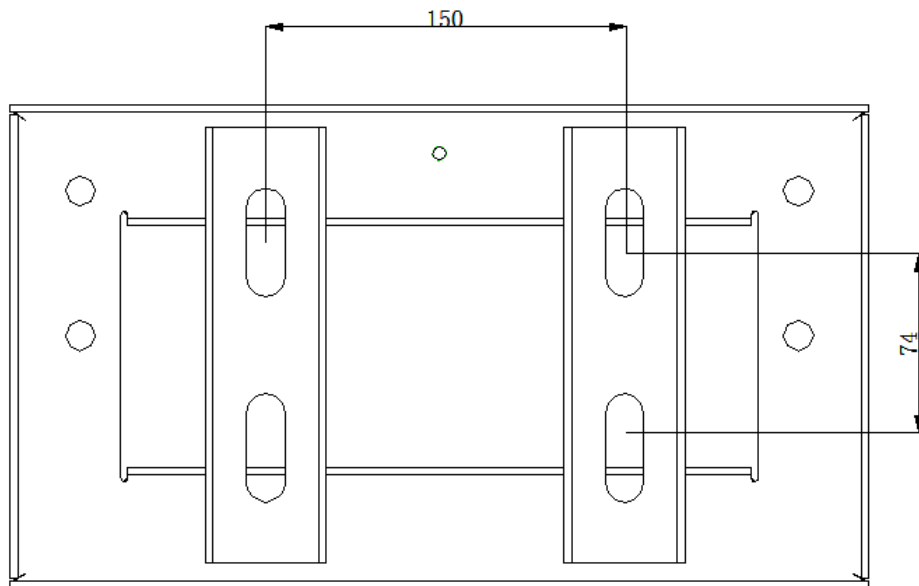

Total barrier Install drawing:

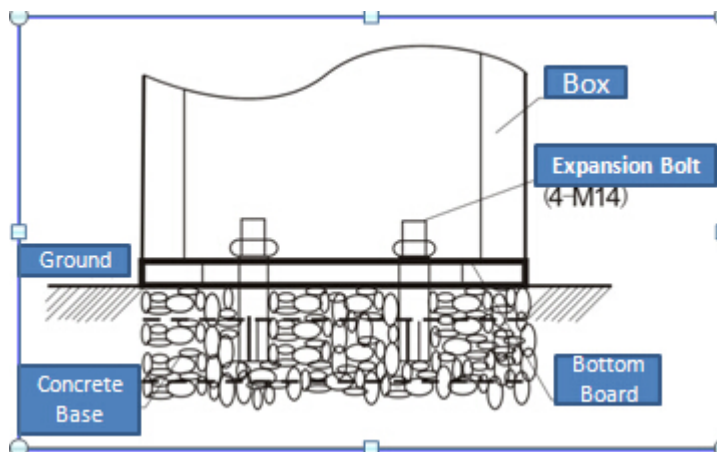

Arm Installation:

- * Release the balance
- * Open the clutch then turn the clutch to horizontal position.
- * Take off all the screws of the arm
- * Install the arm to the barrier box.
- * Make arm to the vertical position and install the spring.

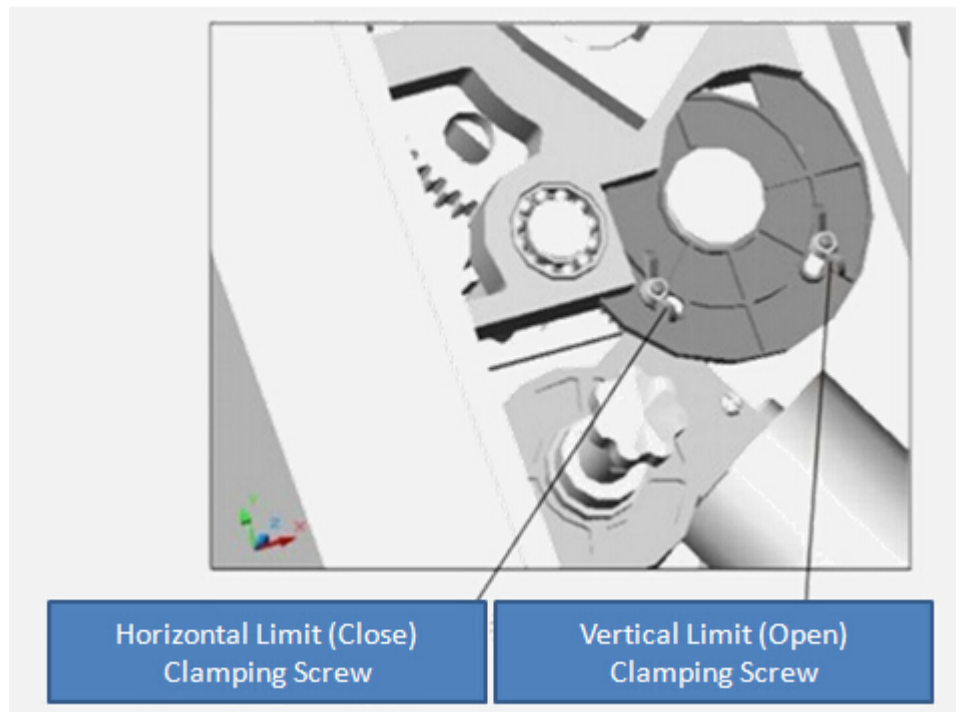

6. Regular problem & Solution

Problem	Possibility	Solution
1、 With power press the button barrier did not working?	<ul style="list-style-type: none"> ①Manual box broken ; ②loop detector broken ; 	<ul style="list-style-type: none"> ①Checking connection of box ; ②Checking the input of loop detector ;
2、 Up & down button no working	<ul style="list-style-type: none"> ①Head controller no working。 	<ul style="list-style-type: none"> ①Change head controller。
3、 Motor notice and arm can not working	<ul style="list-style-type: none"> ①Motor stuck, ; ②Adjust the balance spring to right place ; ③Not enough power supply。 ④Wrong connect with electronic connection and mainboard ; 	<ul style="list-style-type: none"> ① Open the bottom shell of the motor; adjust the screw with slotted screwdriver. ②Adjusting the screw to balance with arm ③Testing the voltage range $110V \pm 10V$。 ④Checking the connection ;
4、 Arm can not at right level	<ul style="list-style-type: none"> ①Clutch in manual model ②Spring tension is too large。 	<ul style="list-style-type: none"> ①Adjust clutch too regular model ; ②barrier in rise position open the top cover and adjusting the fix nut of spring。

7. Maintenance.

Maintenance operations must comply with safety instructions and relevant regulations and standards presented in this manual.

*Road barrier daily maintenance:

*Make periodic inspection to the connecting state of each part. Tighten the nuts or screws if they become flexible to avoid breakdown caused by long term use.

*Make periodic inspection to the condition of system sheltered ground connection place.

Ensure reliable grounding to avoid metal case electric conduction accident.

*Make sure to clean the dust and corrosive material on barrier surface at regular intervals to

avoid rusting and other problems.

*Check the reliability of wire plug and wire, and change engine oil once per year.